

PRESIDIO®

Reliant® Step Guardrail Series

Guardrail Step Kit Instructions

TOOLS REQUIRED: Tape Measure - Screw Gun - Screw/Drill Bit
Chop Saw/Hack Saw - Square - Level

GUARDRAIL STEP KIT CONTENTS

Components	4' Kit	6' Kit	8' Kit
Top Rail - 2" x 3-1/2" Hollow with pre-routed holes	(1)	(1)	(1)
Bottom Rail - 2" x 3-1/2" Webbed with pre-routed holes	(1)	(1)	(1)
Aluminum Insert - for top rail	(1)	(1)	(1)
2" x 3-1/2" Top & Bottom Guardrail Brackets - with nylon post brackets, covers and fasteners	(4)	(4)	(4)
Balusters - 1-1/2" Square or 1-1/2" Colonial (one style per selected kit)	(7)	(11)	(15)

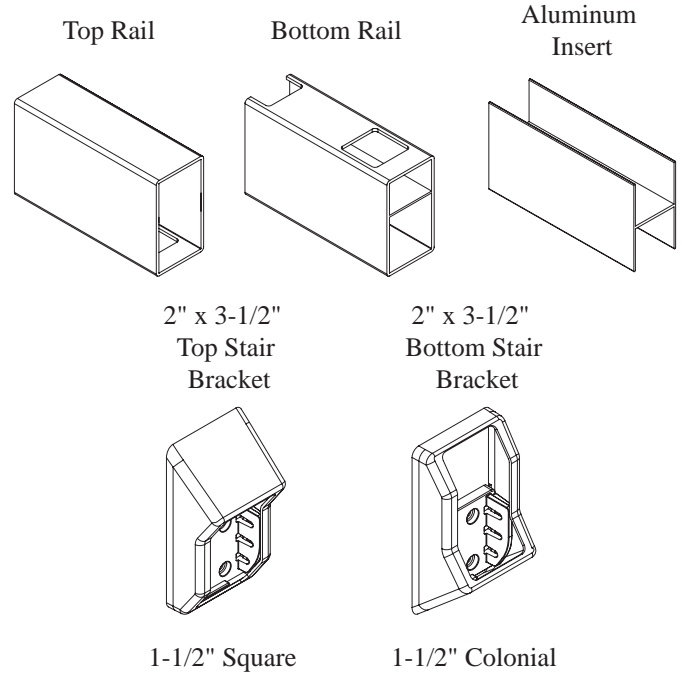

*Accessories items may be purchased separately.

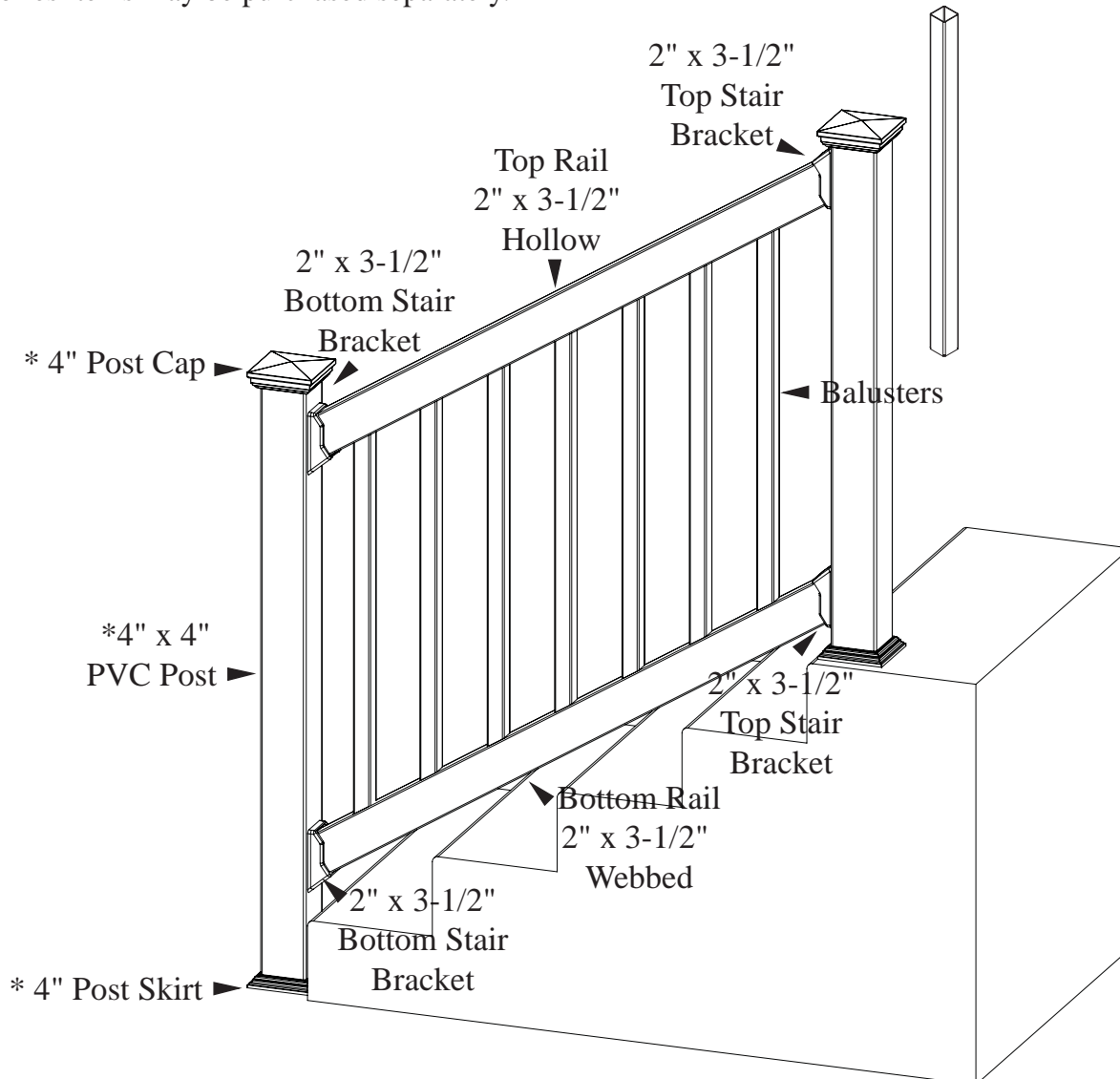

Reliant[®] Guardrail Step Series Assembly Instructions

PRESIDIO[®] Step Kits are designed for a standard 7/11 rise/run or a 32-1/2° angle. The following instructions and illustrations are designed with the upper post support fastened 1-3/8" from the edge of the porch or deck surface and the lower post support fastened 1-3/8" from the foot of the steps. (See illustration in Step 1)

Step 1 - Prepare and install posts and decking. Prepare the posts and mounting surfaces to which the railing section will be attached. A typical installation uses a 4" x 4" vinyl post sleeved over either a 4" x 4" treated wood post, or an LMT Blu-Mount with aluminum or PVC guides. When using PRESIDIO[®] PVC Decking, the upper most 4" x 4" post (installed at the deck or landing surface) should extend 38-1/2" above the wood joist framed structure for 36" high railing systems, and 44-1/2" above the wood joist framed structure for 42" high railing systems. The remaining 4" x 4" staircase posts should be cut 7" longer to accommodate for the 7" stair riser. (See illustration below). Cut and fasten the posts to the wood framing or if you are installing your PRESIDIO[®] guardrail system on a concrete surface, install LMT Blu-Mounts to the concrete pad / staircase following the supplied Blu-Mount installation instructions. Install decking boards over or around post supports. (Please refer to the decking installation instruction manual for the correct installation procedures of the deck boards.) Sleeve the post supports with a 4" vinyl post. The installed post sleeves must be plumb for correct installation of the rail section. If vinyl post skirts are being used at the base of the posts, slide the post skirts into position so that they come to rest around the base of the the 4" x 4" sleeved post.

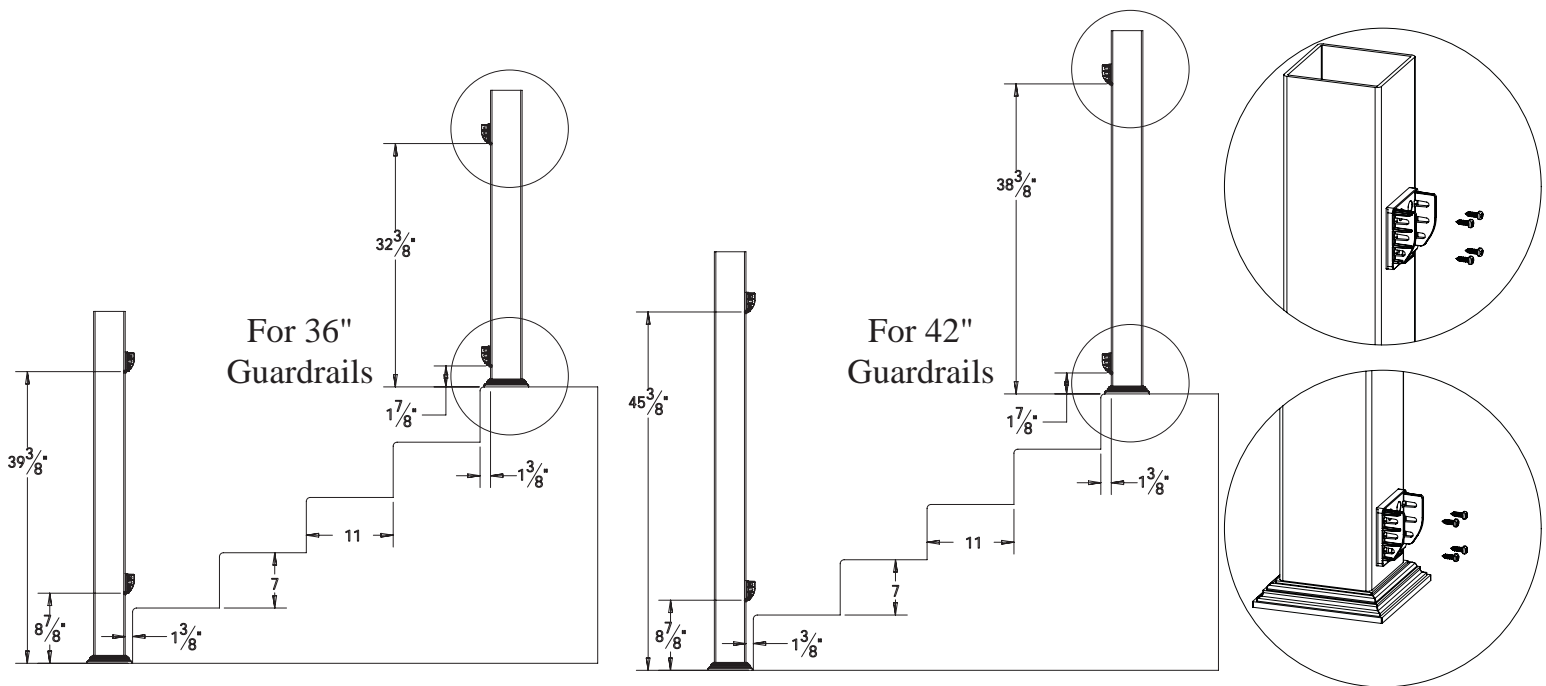

PRESIDIO[®] Step Kits are designed for a standard 7/11 rise/run or a 32-1/2° angle.

Step 2 - Secure post mounting brackets. Attach the nylon post brackets to the sleeved posts by using the (4) #10 x 1-1/2" pan-head screws for the 4" x 4" treated wood post, or the (4) #10 x 1" pan-head screws for the LMT Blu-Mount with aluminum or PVC guides. Measure and secure the bottom nylon post brackets in accordance with the illustration provided in Step 1. Similarly secure the top nylon post brackets to the sleeved 4" x 4" posts as illustrated.

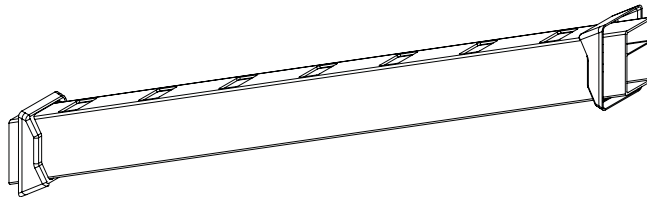

Step 3 - Measure and cut the bottom rail. The bottom rail is identified by having two hollow cavities inside the rail. Measure the distance between the base plates of opposing nylon post brackets keeping the tape measure 1" above the end of the step treads while maintaining a 32-1/2° angle. If cutting of the bottom rail is necessary, cut an equal amount off both ends of the rail so to maintain uniform baluster spacing between the posts. Loosely position the 2" x 3-1/2" bracket covers on opposing ends of the bottom rail.

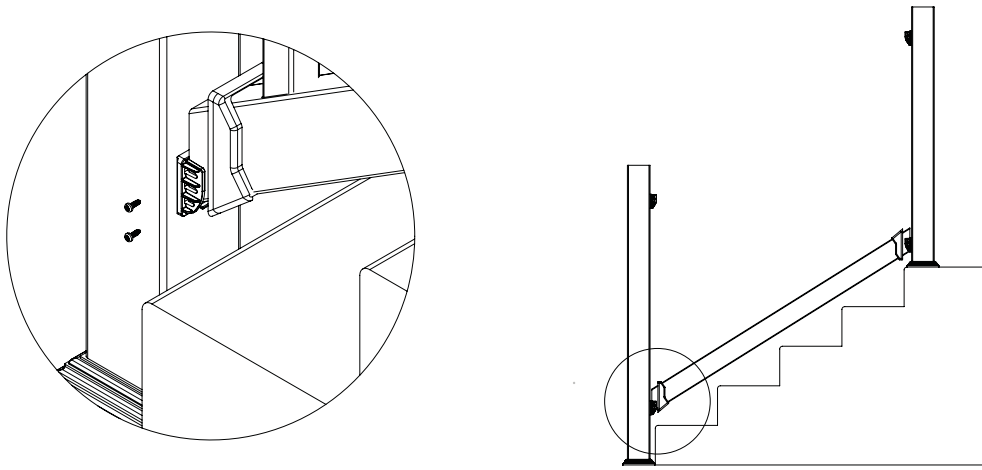

Step 4 - Secure the bottom rail. Attach the bottom rail to the nylon post brackets by using the (4) #10 x 1" pan-head screws. The bottom rail will be 1" off the step tread nosing with the rail inserted correctly into the nylon post brackets. Fasten two screws into each side of the nylon post bracket using the top and bottom slots of the nylon post brackets. Once secured, snap the 2" x 3-1/2" step bracket covers positioned in Step 3 onto the nylon post brackets.

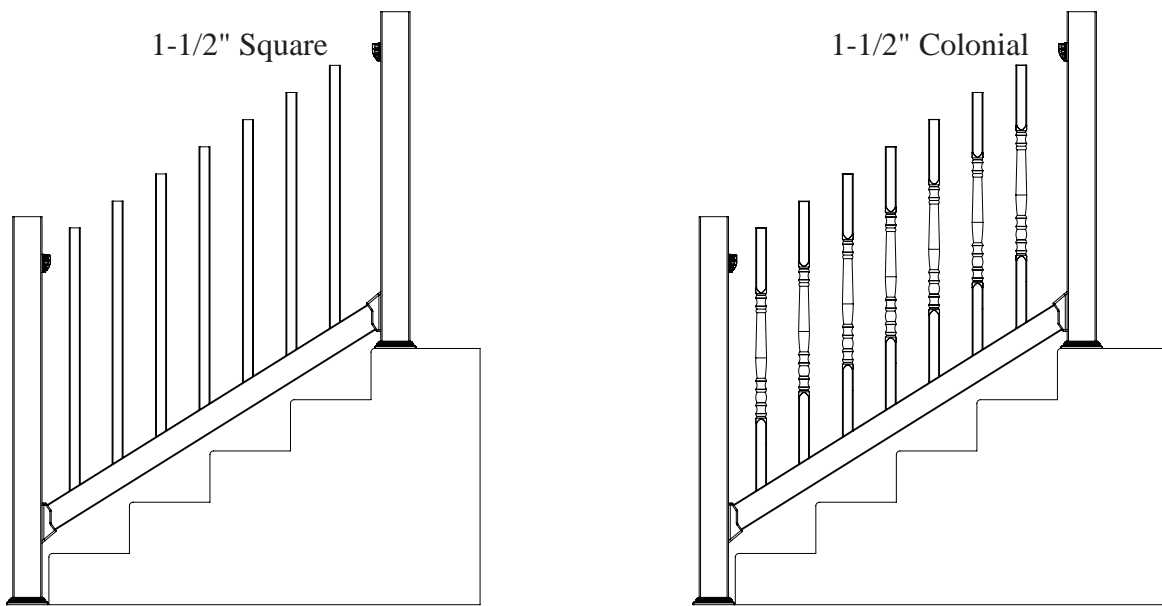

Step 5 - Insert the balusters. Having secured the bottom rail into place, insert the balusters into the bottom rail. If the 1-1/2" colonial balusters are being used make sure the balusters are inserted so the baluster tapers are uniformly installed.

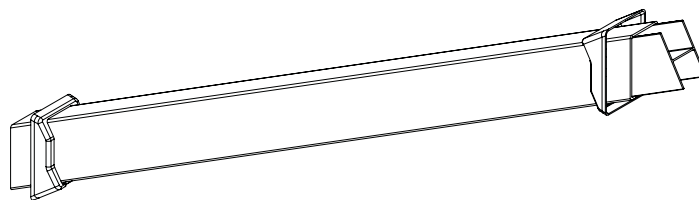

Step 6 - Measure and cut the top rail. If cutting of the top rail is necessary cut an equal amount off both ends of the rail to maintain a uniform baluster spacing between the posts. The rail kits are provided with an aluminum insert that must be used. Cut the aluminum insert to the appropriate length of the measured top rail. Insert the aluminum into the top rail and loosely position the 2" x 3-1/2" bracket covers on opposing ends of the top rail.

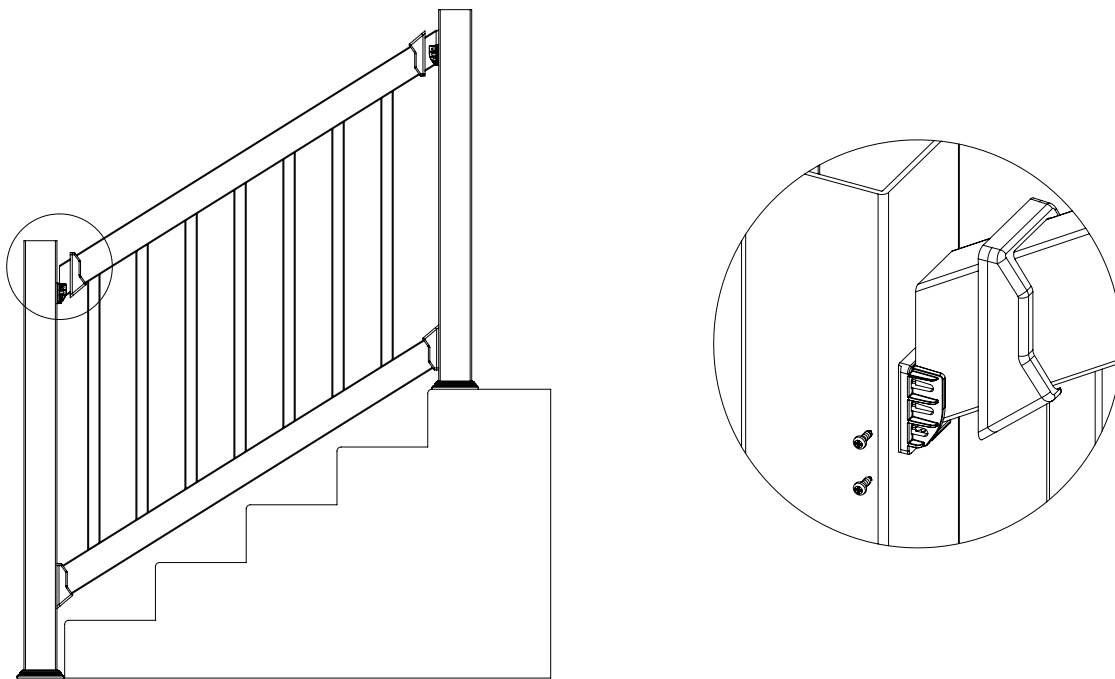

Step 7 - Secure the top rail. Position the top rail over the exposed ends of the balusters so that it is positioned on the resting flange of the installed nylon post brackets. Attach the top rail to the nylon post brackets by using the (4) #10 x 1" pan-head screws. Fasten two screws into each side of the nylon post bracket using the top and bottom slots of the nylon post brackets. Snap the 2" x 3-1/2" bracket covers positioned in Step 6 onto the nylon post brackets.

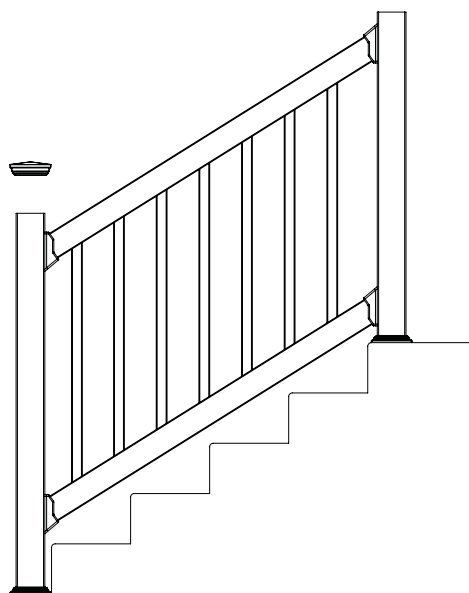

Step 8 - Finish the section. Secure the 4" x 4" post caps onto the post tops by applying PVC adhesive to the internal surfaces of the post caps. Set the caps onto the post tops. Wipe off any excess adhesive.

Please direct product inquires to:

Customer Service Department

Westech Building Products

P.O. Box 567

Mount Vernon, IN 47620

U.S.A

Tel. (812) 985-3628

Fax. (812) 985-2925

info@westechbp.com