

# Multi-Bench

32"H x 58"W x 23"D  
 Seat 17"H x 14½"D



**IMPORTANT! PLEASE BE SURE TO FOLLOW INSTRUCTIONS CAREFULLY, IN THE PROPER SEQUENCE! THANK YOU**

## PARTS LIST

QTY	DESCRIPTION	QTY	DESCRIPTION
4	A. Large planks (1½" x 5½")	1	E. Truss brace (1½" x 3½")
2	B. Small planks (1½" x 3½")	1	F. Legs (Left)
1	C. Arms (Left)	1	F. Legs (Right)
1	C. Arms (Right)	1	Hinge pins
1	D. Cross Brace	4	1¼" Bolts with nuts

### STEP 1

Start assembly of bench bottom by inserting planking into the slots of one leg part (F.). Use (2) large planks (A.) in the outside slots and (1) small plank (B.) into the middle slot. (Note: Illustration #1 shows the front of the bench to be where the leg hinge knuckle is closest to.)

### STEP 2

Take the truss brace (E.) and insert it into the brace attachment point (Illustration #1) on the completed leg. Do not secure brace with bolts and nuts yet.

### STEP 3

Attach other leg (F.) into the planking and truss brace, making sure planking is completely inserted into all leg slots. Now attach the truss brace (E.) to the legs by aligning the two pre-drilled holes and installing the 1¼" bolts and nuts into both legs.

### STEP 4

Attach and center the cross brace (D.) to the truss brace (E.) by sliding it into place under the bench (Illustration #2). The cross brace should be centered and touching the bottom of the bench. Turn bench upright.

### STEP 5

Assemble the bench back by inserting the planking in the arms (C.) Use (2) large planks (A) in the outside slots and (1) small plank (B.) in middle slot. Insert all (3) planks into (1) arm and then slide the other arm onto the planks. Make sure that each plank is completely inserted into each arm slot.

### STEP 6

Attach bench back to bench bottom by aligning the slot at the bottom front of the arm with the knuckle on the top of the leg (this makes up the hinge of the bench). Make sure the back of the arm touches the top of the bench bottom (see Illustration #4). After these are, aligned, insert the plastic hinge pin through the hole of the hinge.

Clean your Multi - Bench by using a mild detergent or all purpose spray cleaner and water.

**CAUTION: SUPERVISION IS NECESSARY WHEN CONVERTING THE BENCH INTO A TABLE TO AVOID PINCH POINTS.**

Illustration #1

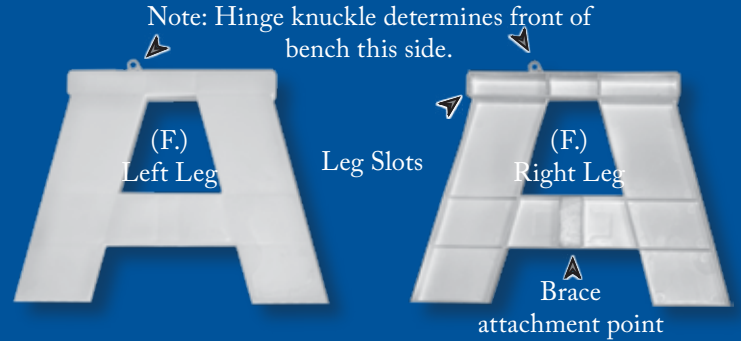

Illustration #2

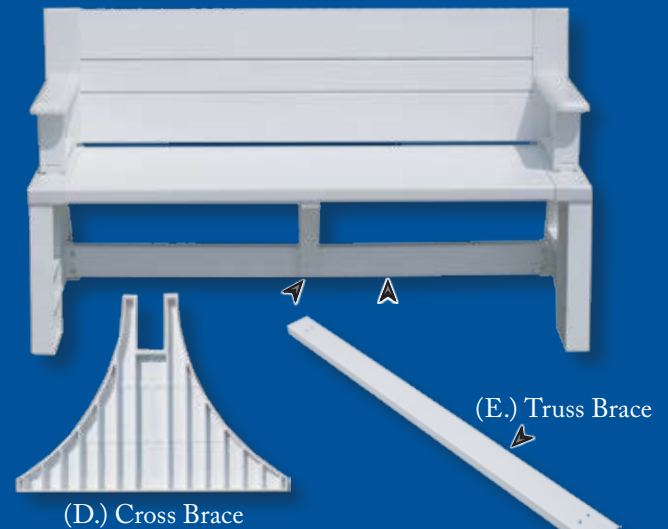

Illustration #3

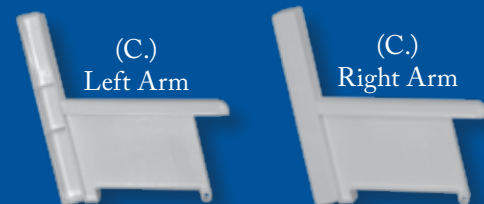

Illustration #4

